

**C TP-108**

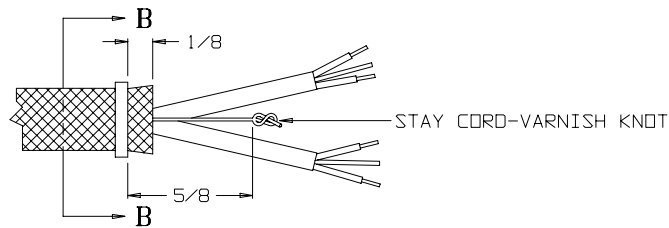
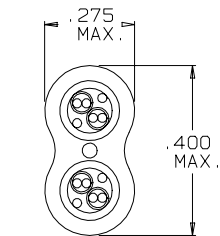
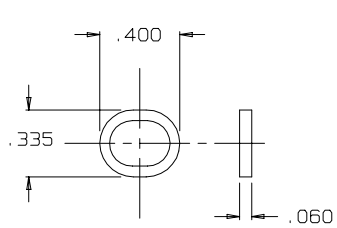
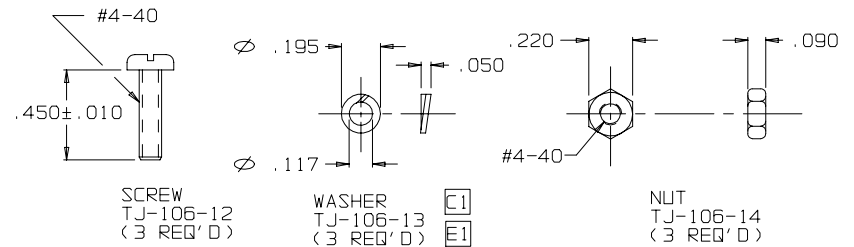
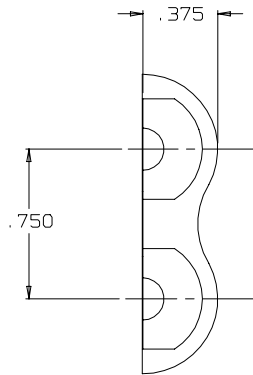
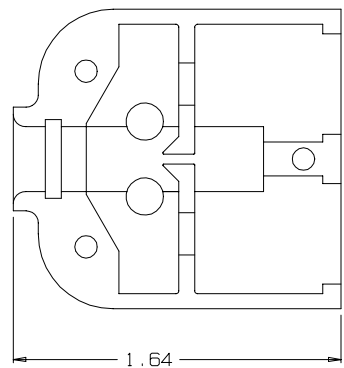
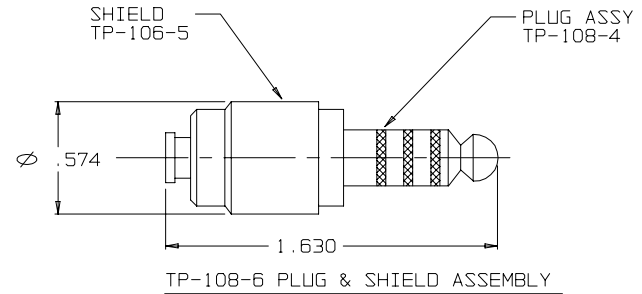
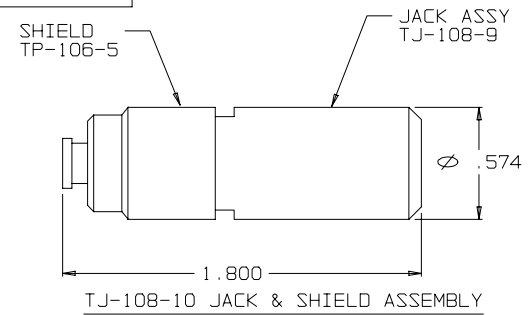
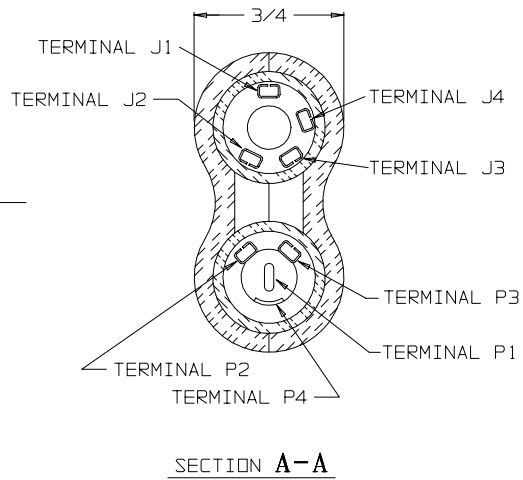
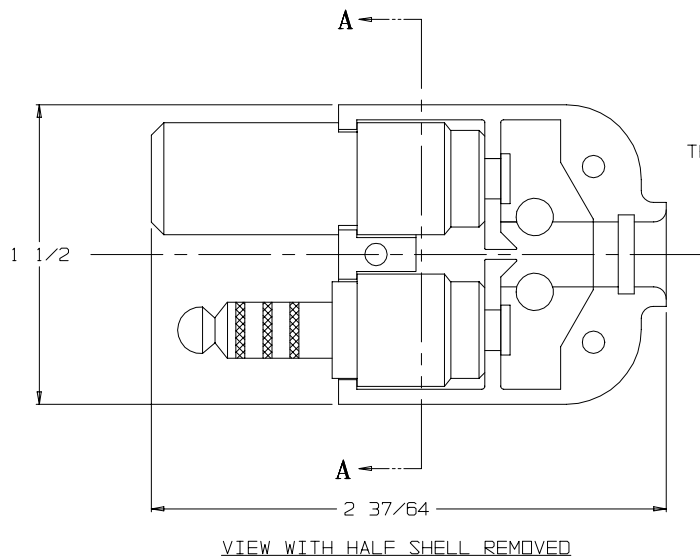

- F1** NOTES:  
 1) ALL NICKEL PLATING SHALL BE OF SUFFICIENT THICKNESS TO PROVIDE CORROSION PROTECTION. (REF QQ-N-290-A, CLASS 1)  
 2) WIRING CALL OUTS ARE FOR REF ONLY

THIS DOCUMENT CONTAINS PROPRIETARY INFORMATION OF NEXUS, INCORPORATED AND SUCH INFORMATION MAY NOT BE DISCLOSED TO OTHERS FOR ANY PURPOSE OR USED FOR ANY PURPOSE WITHOUT THE WRITTEN CONSENT OF NEXUS.

RING, STRAIN RELIEF  
TJ-106-10A  
(1 REQ'D)

SECTION B-B  
STRAIN RELIEF  
CLAMP TJ-106-10A  
AFTER CRIMPING  
SCALE: 4:1

C	REDRAWN IN CAD CORRECTED ERRORS	476	2/24/04	EWT
B	.395 WAS .400	283	12/4/97	
A	CORRECTED TO DF P3, P4 & P3, P4	197	10/11/95	LS
LET.	REVISION	CN #	DATE	CHK.

DWN. BY	IDH	DATE	MATERIAL	SEE FIELD OF DRAWING
CHECKED BY	L SMITH	DATE	FINISH	N/A
APPR. BY		DATE	WEIGHT	SCALE 2:1
UNLESS OTHERWISE SPECIFIED DIMENSIONS ARE IN INCHES TOLERANCES ON FRACTIONS DECIMALS ANGLES			TITLE	TP-108 PLUG-TELEPHONE-BIAXIAL SHIELDED (8) CONDUCTOR
DO NOT SCALE DWG.			SHEET 1 OF 1	SIZE C
				DWG. NO. TP-108