

ITEM #	PART #	QTY	DESCRIPTION	MATERIAL
1	AP-155-1	1	SHELL ASS'Y	GLASS FILLED NYLON & 303 SS
2	AP-125-6	1	INSERT ASS'Y	DIALLYPHTHALATE, TYPE SDGF & GOLD PLATED BRASS
3	AP-105-5	1	STRAIN RELIEF	NYLON
4	AP-105-6	1	FERRULE	STAINLESS STEEL
5	AP-105-8	1	NUT CLAMP	NYLON, BLACK PER MIL-P-17091

C AP-155

TABLE	
AUDIO PLUG #	MILITARY PART #
AP-155	M55116/5

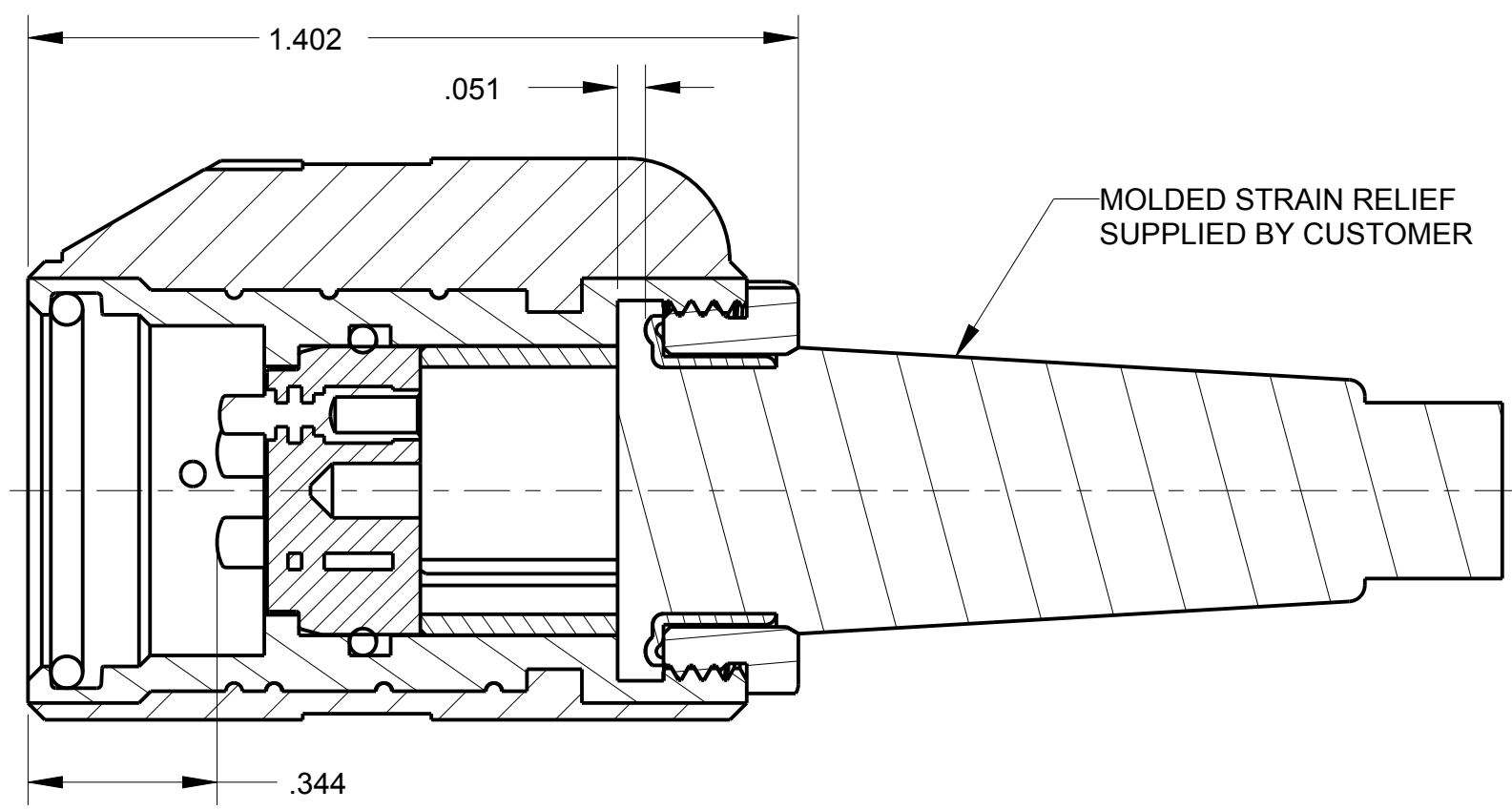
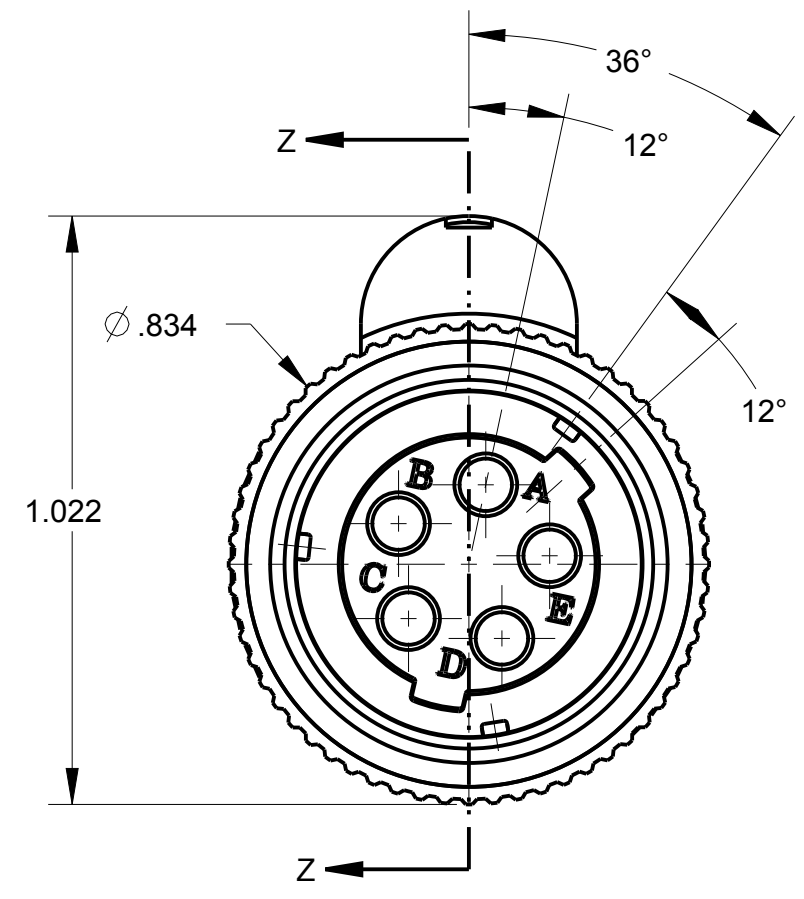
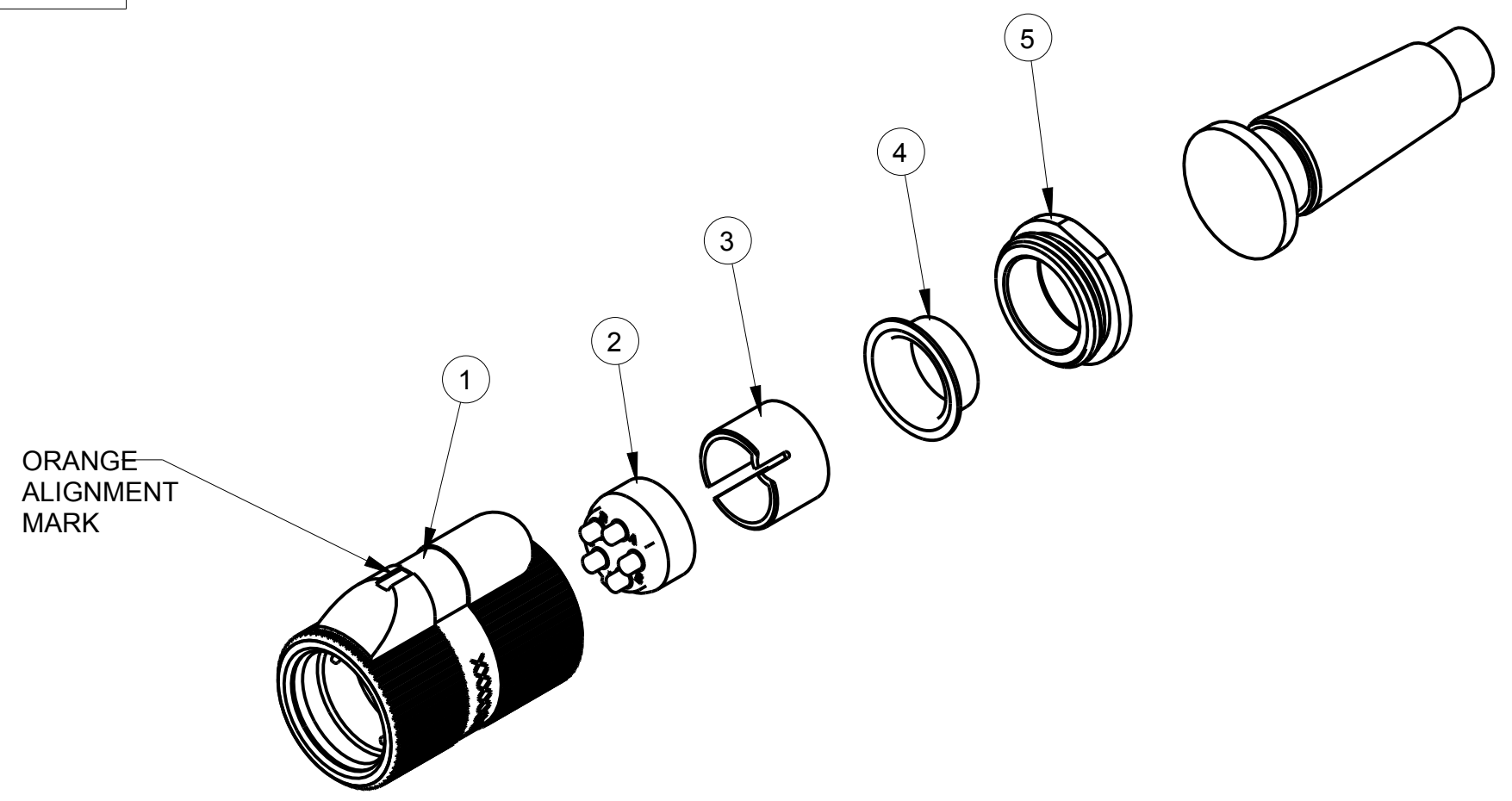

SECTION Z-Z

NOTES:
 1) UNLESS OTHERWISE SPECIFIED, CONNECTOR MEETS ALL GENERAL REQUIREMENTS & SPECIFICATIONS OF MIL-C-55116

THIS DOCUMENT CONTAINS PROPRIETARY INFORMATION OF NEXUS, INCORPORATED AND SUCH INFORMATION MAY NOT BE DISCLOSED TO OTHERS FOR ANY PURPOSE OR USED FOR ANY PURPOSE WITHOUT THE WRITTEN CONSENT OF NEXUS.

				DWN. BY	MNF	DATE	2/4/97	MATERIAL	
				CHECKED BY	L SMITH	DATE	9/9/97	FINISH	
				APPR. BY	L SMITH	DATE	9/9/97	WEIGHT	SCALE = 1.00 :1
				UNLESS OTHERWISE SPECIFIED DIMENSIONS ARE IN INCHES & OR [mm]				TITLE	
				TOLERANCES:				AUDIO PLUG	
				DECIMAL: ±XX[X.X] ±.01[0.3] ±.003[0.08]				NEXUS STAMFORD, CONN	
				FRACTION: ±XXX ± 1/64				DO NOT SCALE DWG. SHEET 1 OF 1	
				ANGLES: ±X ° ±5 °				SIZE	DWG. NO.
								C	AP-155