

ITEM #	PART #	QTY	DESCRIPTION	MATERIAL
1	AP-176-1	1	SHELL ASS'Y	GLASS FILLED NYLON & 303 SS
2	AP-146-6	1	INSERT ASS'Y	DIALLYPHTHALATE, TYPE SDGF & GOLD PLATED BRASS
3	AP-105-5	1	STRAIN RELIEF	NYLON
4	AP-116-16	1	WASHER	RUBBER
5	AP-136-10	2	WASHER	STAINLESS STEEL
6	AP-136-13	1	NUT ADAPTER	STAINLESS STEEL
7	AP-116-14	1	BUSHING	RUBBER, BLACK
8	AP-116-10	1	WASHER	STAINLESS STEEL
9	AP-116-11	1	SPRING	302 STAINLESS STEEL
10	AP-116-15	1	STUD	ANODIZED ALUMINUM ALLOY

C AP-186

NOTES:
 1) UNLESS OTHERWISE SPECIFIED, CONNECTOR MEETS ALL GENERAL REQUIREMENTS & SPECIFICATIONS OF MIL-C-55116

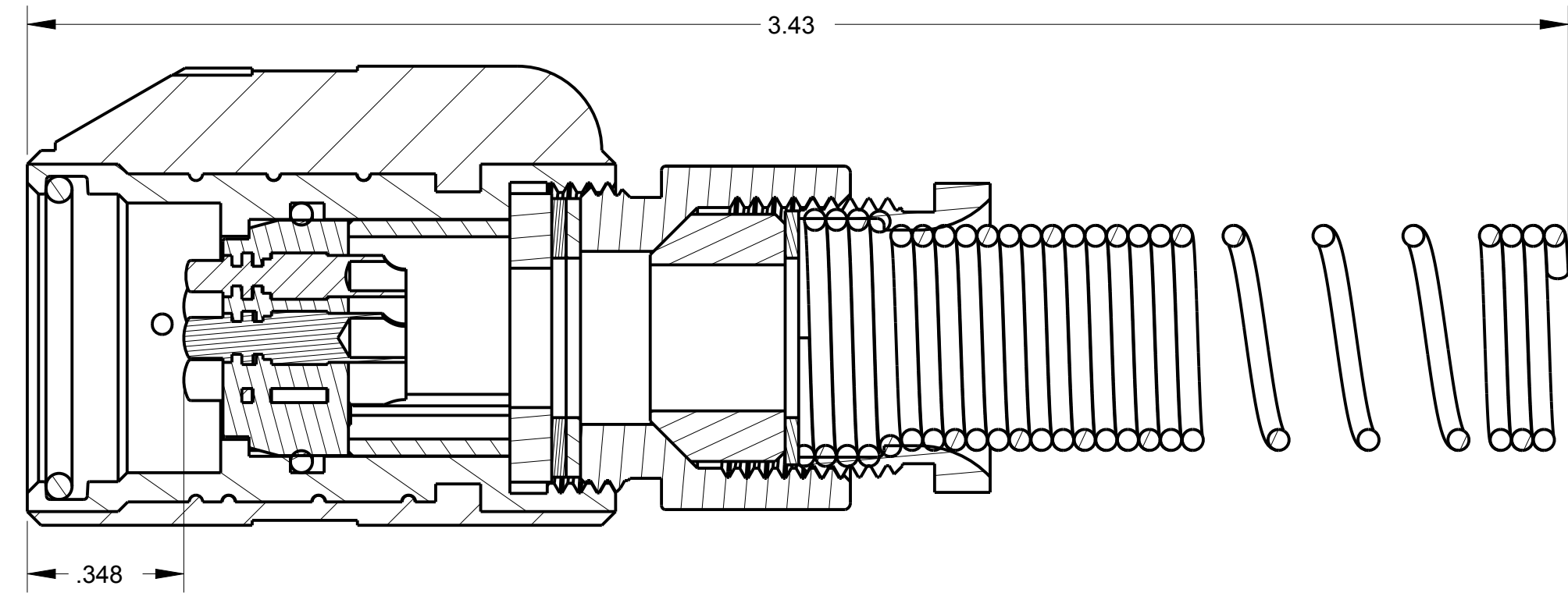
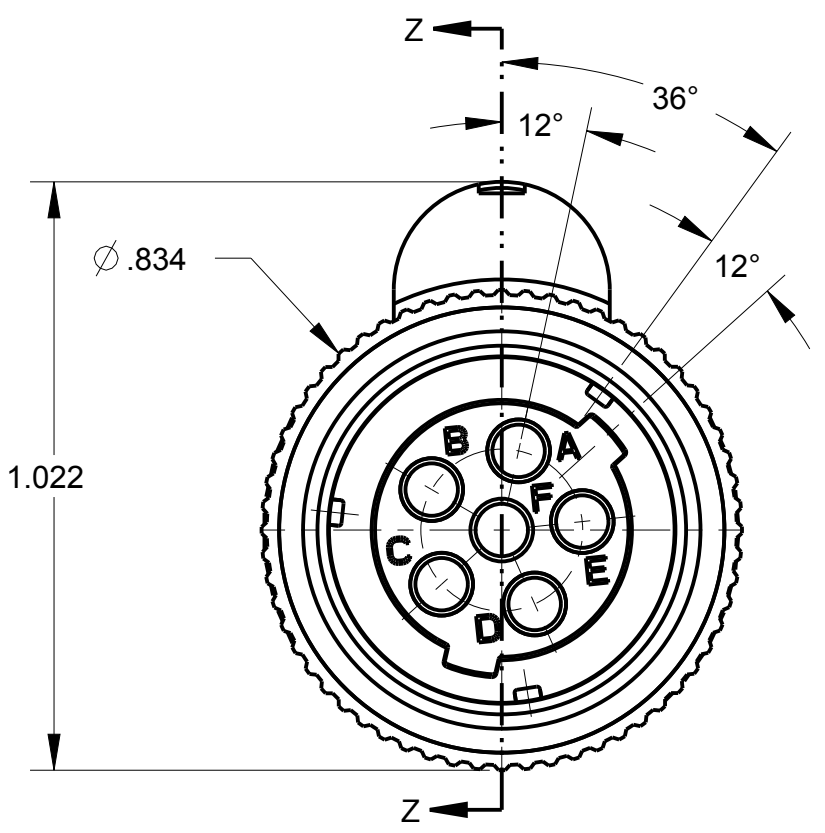
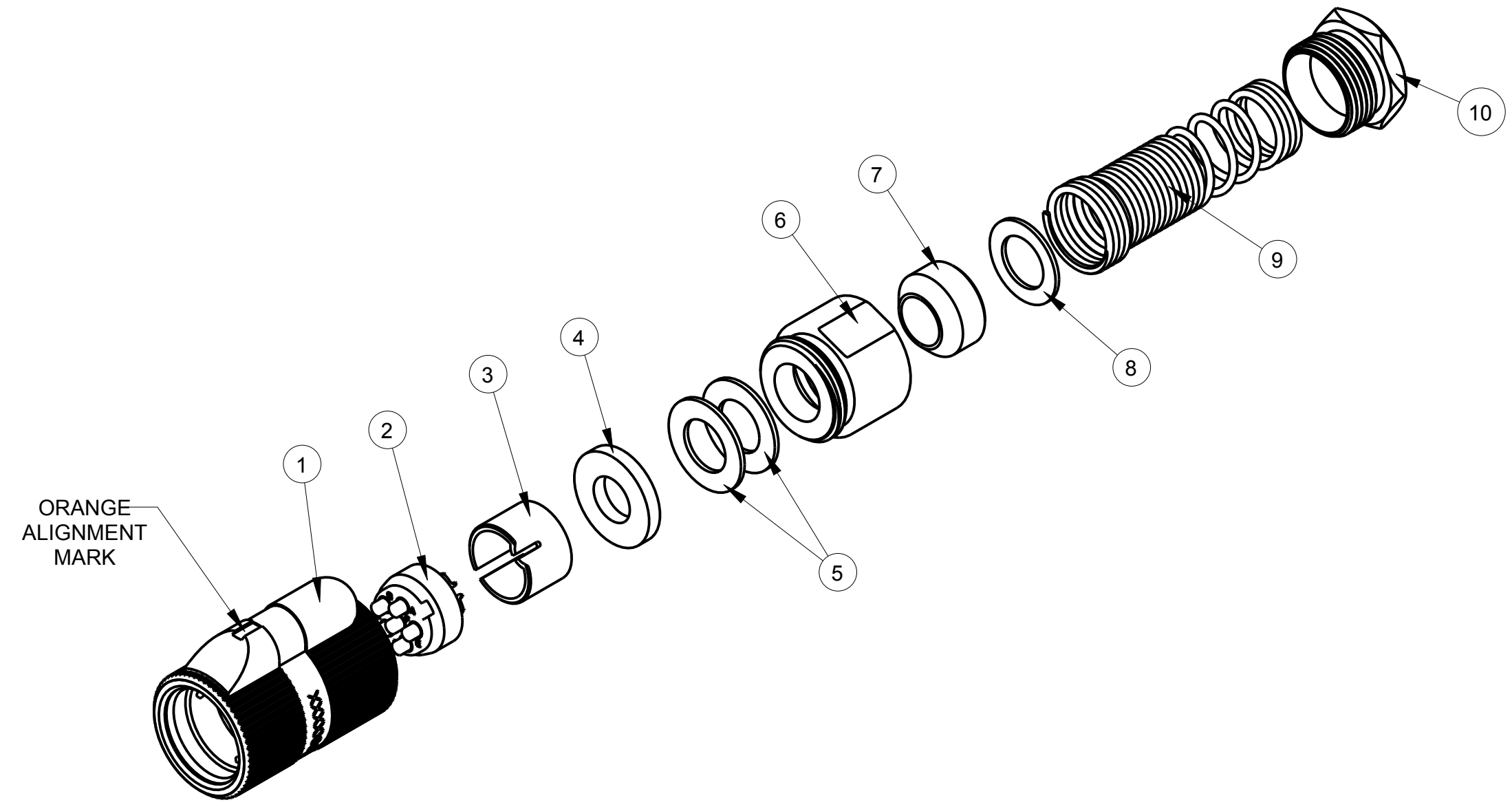

LET.	REVISION	CN #	DATE	CHK
C	CHG; AP-176-2 TO AP-176-1	101	5/14 2012	HR
B	1) REMOVE PRESSED IN PIN 2) ADD (SEE NOTE 2) 3) ADD WASHER, 2-AP136-10 4) ADD NOTE 2 5) IN MAT'LS REMOVE WITH SS PINS	045	2/12 2010	GPH
A	INITIAL RELEASE		1/2 2008	EWT

DWN.BY	EWT	DATE	1/2/08
CHECKED BY		DATE	
APPR.BY		DATE	

MATERIAL	
FINISH	
WEIGHT	SCALE = 1.00 :1
TITLE	
AUDIO PLUG	
DO NOT SCALE DWG.	SHEET 1 OF 1

NEXUS
 STAMFORD, CONN
 SIZE DWG. NO.
C AP-186

THIS DOCUMENT CONTAINS PROPRIETARY INFORMATION OF NEXUS, INCORPORATED AND SUCH INFORMATION MAY NOT BE DISCLOSED TO OTHERS FOR ANY PURPOSE OR USED FOR ANY PURPOSE WITHOUT THE WRITTEN CONSENT OF NEXUS.