

B MAJ-16-00

ITEM	PART NO.	QTY	DESCRIPTION	MAT'L / FIN
1	MAJ-10-32	1	O-RING, PANEL MOUNT	PASSIVATED SST
2	MAJ-10-33	1	NUT, PM-MAJ	RUBBER
3	MAJ-16-01	1	7 COND. REC. PM	PASSIVATED SST

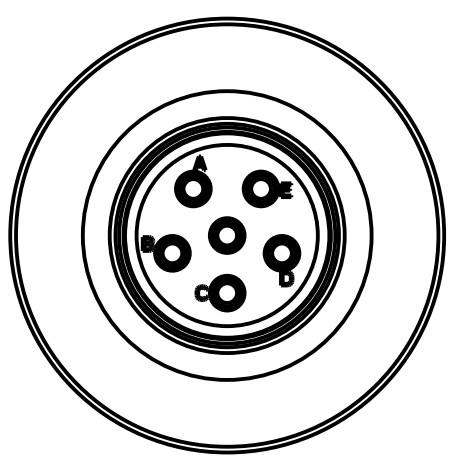
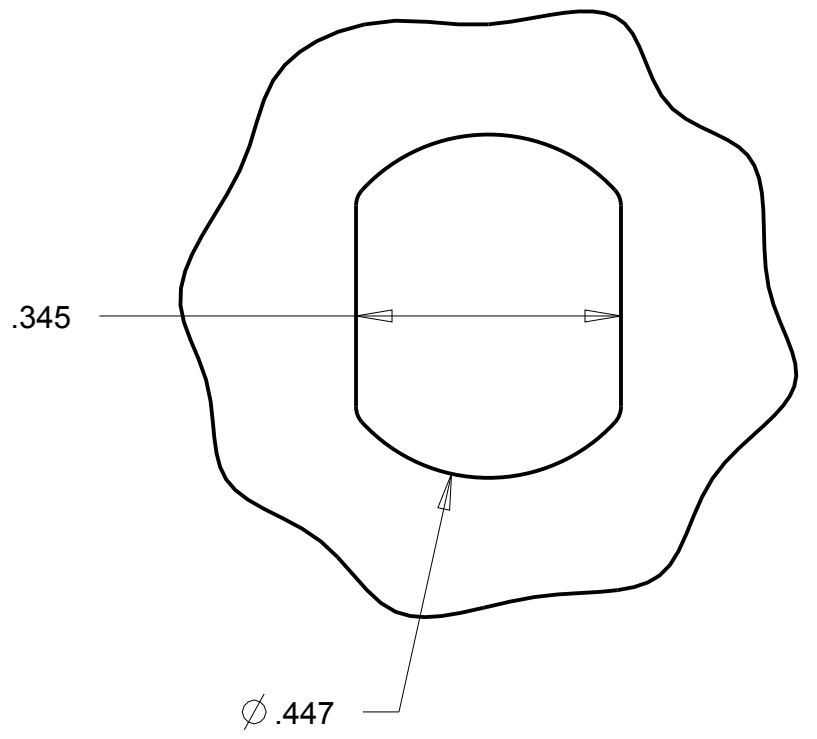
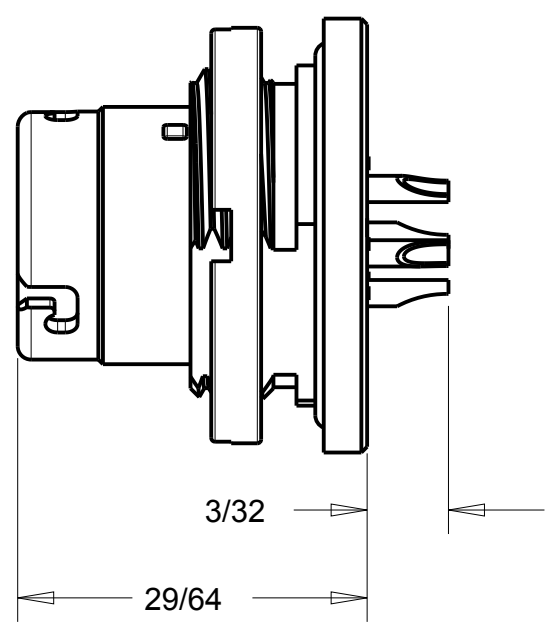
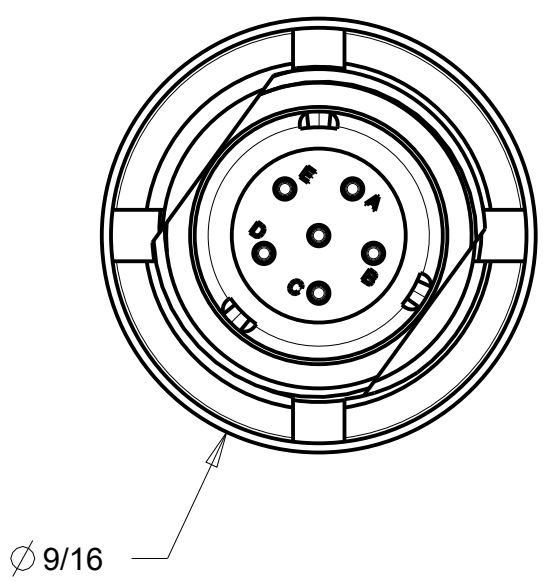
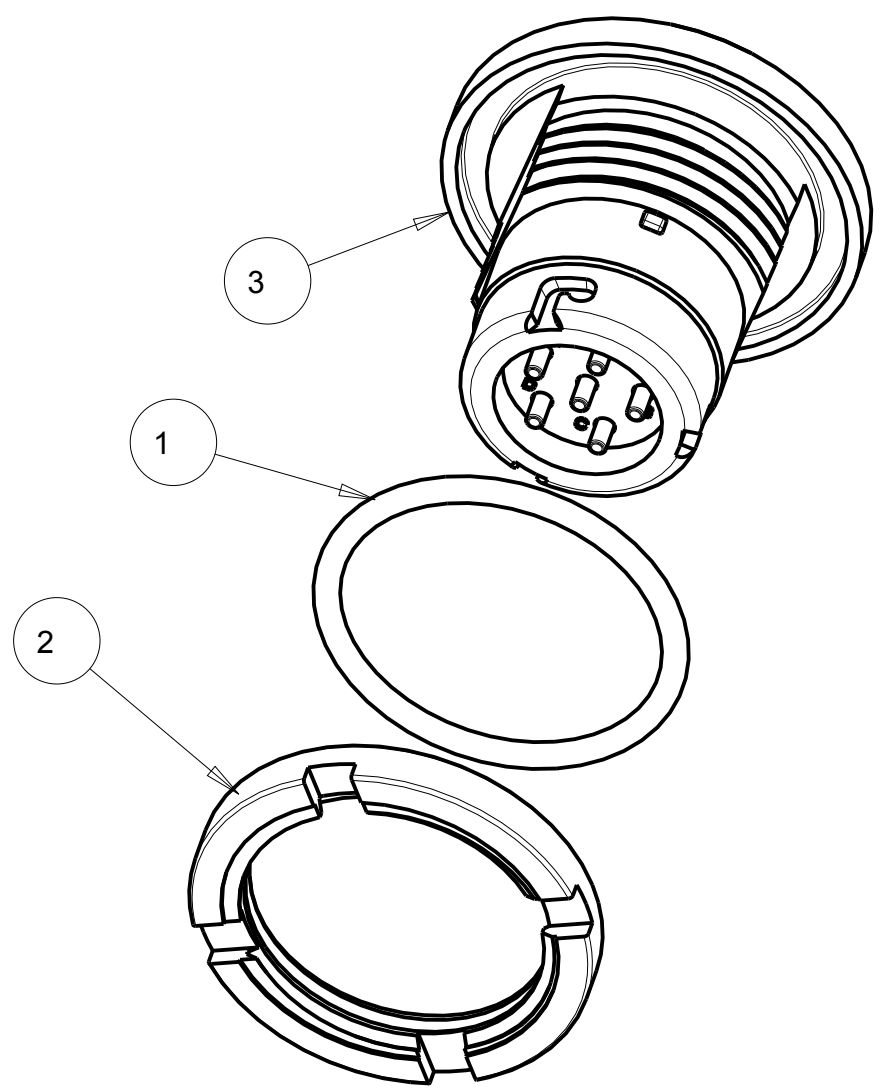

THIS DOCUMENT CONTAINS PROPRIETARY INFORMATION OF NEXUS, INCORPORATED AND SUCH INFORMATION MAY NOT BE DISCLOSED TO OTHERS FOR ANY PURPOSE OR USED FOR ANY PURPOSE WITHOUT THE WRITTEN CONSENT OF NEXUS.

LET.	REVISION	CN #	DATE	CHK.
D	DEL: HSG EDGE ROLLED OVER TO RETAIN INSERT	176	6/10 2013	HR
C	SHOW PIN SPACING		06/07 2010	LDE
B	MODIFY PANEL CUT WAS A SIZE & MAT'L		06/04 2010	LDE
A	RELEASE		01/26 2010	LDE

DWN.BY	LDE	DATE	26-Jan-10
CHECKED BY		DATE	
APPR.BY		DATE	

UNLESS OTHERWISE SPECIFIED:
DIMENSIONS ARE IN INCHES &/OR (mm)
TOLERANCES:
DECIMAL: .XX[X.X] .XXX[X.XX]
± .01[0.3] ± .003[0.08]
FRACTION: X/X ± 1/64 ANGLES: X ± .5°

MATERIAL	
FINISH	
WEIGHT	SCALE = 4.00 :1
TITLE	
6 COND. REC. PANEL MOUNT	
DO NOT SCALE DWG.	SHEET 1 OF 1

NEXUS
STAMFORD, CONN

SIZE **B** DWG. NO. MAJ-16-00